



## **AGENDA**

### **Parks, Beaches, and Recreation Commission**

### **City of Pacifica**

---

**Regular Meeting – 7 PM**  
Wednesday, September 27, 2023  
2212 Beach Blvd. Pacifica, CA 94044

#### **CALL TO ORDER**

#### **7:00 PM REGULAR MEETING**

#### **I. PLEDGE OF ALLEGIANCE**

#### **II. ROLL CALL**

#### **III. APPROVAL OF MINUTES:** 08/23/2023 Meeting Minutes

#### **IV. ADOPTION OF AGENDA**

#### **V. SPECIAL PRESENTATION**

A. Introduction of New Staff- Recreation Manager, Scott Leslie

#### **VI. ORAL COMMUNICATION**

This is the time set aside for the public to address the Commission on items not appearing on the agenda, public input will be considered for items at this time. Please state your name for the record when addressing the Commission. Statements will be limited to three (3) minutes.

#### **VII. ITEMS FOR CONSIDERATION**

A. Priority Park update

#### **VIII. REPORTS, ANNOUNCEMENTS, AND CORRESPONDENCE FROM COMMISSIONERS**

#### **IX. REPORTS FROM STAFF**

Director Bob Palacio

#### **X. ADJOURNMENT**

**Next Regular Meeting:** Regular meeting – October 25, 7:00pm

**The City of Pacifica will provide special assistance for disabled citizens upon at least 24-hour advance notice to the City Manager's office (738-7301). If you need sign language assistance or written material printed in a larger font or taped, advance notice is necessary. All meeting rooms are accessible to the disabled.**



**Minutes  
Parks, Beaches, and Recreation Commission  
City of Pacifica**

**REGULAR MEETING – 7 PM**

Wednesday, August 23, 2023  
2212 Beach Blvd. Pacifica, CA 94044

**CALL TO ORDER:**

**Chair Abbott:** called the meeting to order at 7:02 pm.

**I PLEDGE OF ALLEGIANCE:**

**Commissioner Benton-Shoemaker:** led the Pledge of Allegiance.

**II ROLL CALL:**

**Commissioners Present:** Chair Abbott, Commissioners: Benton-Shoemaker, Phillips, Rodriguez, and Torres

**Commissioners Absent:** Commissioner Heywood and Nicolari (excused)

**Staff Present:** Director Bob Palacio, Recreation Supervisor Anthony Schriver, Recreation Coordinator Lexi Macario and Recreation Specialist Rebecca Collier

**III APPROVAL OF MINUTES:**

**Chair Abbott** called for a motion to approve the minutes June 28, 2023. **Motion was made by Commissioner Phillips, seconded by Commissioner Benton-Shoemaker, motion carried 5-0.**

**IV ADOPTION OF THE AGENDA:**

**Chair Abbott** called for vote to approve the agenda of the 08/23/2023 meeting. **Motion carried 5-0.**

**V INTRODUCTION OF NEW COMMISSIONER**

Introduction of Commissioner Mark Torres: He has lived in Pacifica for the past 12 years with his family. He is currently working for San Francisco Utilities Commission. He is excited to join the Parks, Beaches, and Recreation (PB&R) Commission. He intends to focus on improving and development of more recreation sports fields and facilities in the City of Pacifica.

**VI SPECIAL PRESENTAION:**

Recreation Coordinator Lexi Macario and Recreation Supervisor Anthony Schriver introduced themselves to the Commission. Coordinator Macario gave an overview of the Recreation Programs and Facilities. She recapped and elaborated on the following topics:

- Youth and Teen
- Summer Adventure Camp
- Youth Advisory Board (YAB)
- Special Events – Spring Egg Hunt, Jr. Olympics, and 4<sup>th</sup> of July

- Contracted Classes
- Community Center Rentals

Recreation Supervisor Schriver gave an overview of the Aquatics programs. He recapped and elaborated on the following topics:

- Water Aerobics
- Swimming Lessons
- Wet and Wild Camp
- Surf Survival Apnea Course
- Lifesaving Buoy Station
- 2023 Rocket Run

Summary of questions from Commissioners:

- 1) Is focus on recurring programs/events growth or refining?
- 2) How close are participation and attendance for programs/events compared to pre-pandemic levels?
- 3) Why Jr Olympic timing system that was donated by the Lions Club was not being utilized?

Staff Response:

- 1) Focus is on both growth and refining programs/events. Areas of focus in the future will be utilizing the community center for contract programs once the new Civic Center is complete and staff have moved. Programs/Event staffing levels are important in any event or program quality.
- 2) Across all programs and events participation numbers are steadily increasing to pre-pandemic levels. Programs had sold out quickly and seeing returning participants, which indicates quality of programs. Focus moving forward will continue with producing quality programs/ events and then continue to expand with other new programs/events.
- 3) Jr Olympic timing equipment and software became obsolete and was more expensive to update the software and equipment then hiring a timing company with the most up to date equipment.

**VII ORAL COMMUNICATION:**

None

**VIII ITEMS FOR CONSENT:**

- A. Administrative Narrative
- B. Aquatics update
- C. Child Care update
- D. Recreation, Youth and Teen Program update
- E. Senior and Food Services update

**Chair Abbott** called for a motion to approve the Items for Consent. **Motion was made by Commissioner Benton-Shoemaker, seconded by Commissioner Phillips, motion carried 5-0**

**IX ITEMS FOR CONSIDERATION:**

- A. Priority Parks-** Director Palacio gave a status update on the sixty-five percent construction documents of the four priority parks (Brighton, Marvilla, Imperial and Skyridge) cost. All four parks construction plan estimates came in over the original budget of \$1.2 million for all four parks. The project extensive scope of work includes, new pathways, vegetation planting, irrigation, and playground equipment installation. Cost also included construction, contingency and design

costs. City staff did a value engineering cost review with NCE Consulting. After review staff asked, NCE for adjustments and updated cost estimate to meet the original budget of \$1.2 million. NCE made reduction in some materials such as pavement and surfacing along with some reconfiguration in some of the park's update. Staff will update PB&R Commission with new cost estimates for each park once new information has been received. In the future, staff will develop uniform signage to create cohesiveness and brand recognition for all City of Pacifica Parks.

**Summary of PB&R Commission suggests on design elements:**

- 1) Larger concrete seating be replaced with more all age friendly
- 2) Multi stream trash bins instead of single bins
- 3) Review of dog waste station's locations
- 4) Bike racks/parking in all parks
- 5) Review of reducing element(s) at Imperial Park, if a need to reduce cost to stay within budget of the project
- 6) Improved signage at all parks
- 7) Additional picnic seating at Skyridge park.

**X REPORTS, ANNOUNCEMENTS, AND CORRESPONDENCE FROM COMMISSIONERS:**

Commissioners gave updates on their liaison assignments and community involvement.

**XI REPORTS FROM STAFF:**

Director Palacio: Gave updates on the following:

- **Surf Camp/School Policy:** Staff will meet with surf camp providers on August 30, 2023. Surf camp providers will have the opportunity to give a review of their summer and address any challenges and celebrate success.
- **Play Structure Improvement:** Consist of replacing the existing play structures with new updated equipment and are less comprehensive than the Priority Parks Projects.
  - Fairway Park: Construction began Aug 23, 2023
  - Saltaire Park: Waiting on construction date
  - Oddstad Park: More information in the future
- **Teens:** Director Palacio and Recreation Supervisor Schriver took a group of twenty (20) youth skateboarders on two trips and visited five skateparks around the Bay Area and one waterpark in August.
- **Bike Park:** Pacifica Bike Park Committee, Commissioner Phillips, and Staff met with American Ramp Company (ARC) to solicit another quote for design concept and outreach services. Staff submitted a Recreational Trails Grant Application with the California State Department of Parks and Recreation in the amount of \$1.55M for design and construction of a Bike Park, the grant requires a 12% match from the city.
- **Marketing and Branding:** Working with Staff and Commissioner Rodriguez to implement a new marketing plan and logo.
- **Facilities:** Staff applied for \$3.5 million grant for upgrades to Pacifica Community Center with California Strategic Growth Council. The building is a gathering space for the public during disasters, the needs updated HVAC, electrical, flooring and more. At Fairway Park all three backstops will be replaced in the next few months.

**XII ADJOURNMENT:**

**Chair Abbott:** asked for motion to Adjourn. **A motion was made by Commissioner Phillips, seconded by Commissioner Rodriguez. Motion carried 5-0.**

**Next Regular Meeting:** Regular Meeting – September 27, 2023, 7:00pm

Respectfully submitted by,  
Rebecca Collier, Recreation Specialist  
Pacifica Parks, Beaches, and Recreation

X \_\_\_\_\_  
Pacifica Parks, Beaches, and Recreation Commission  
Chair Cindy Abbott



WOOD PIERS



FENCE MURAL



CONCRETE PEBBLE SEATING

CITY OF PACIFICA FOR  
PRIORITY PARKS

OWNER

CITY OF PACIFICA  
540 CRESPI DRIVE,  
PACIFICA CA 94044

NO.	DATE	DESCRIPTION
5/11/2023	65% SUBMITTAL	

PROJECT NO.:	1004.14.55
DESIGNED BY:	MSG
DRAWN BY:	CDV & IMA
CHECKED BY:	MSG DATE 5/11/23
DATE:	5/11/23

This drawing is the property of NCE, including all patented and patentable features, and/or confidential information and its use is conditioned upon the user's agreement not to reproduce the drawing, in whole or part, nor the material described therein, nor the use of the drawing for any purpose other than specifically permitted in writing by NCE.

SHEET TITLE

BRIGHTON PARK  
MATERIAL PLAN

DRAWING

L 1.1.2

SHEET 4 OF 28

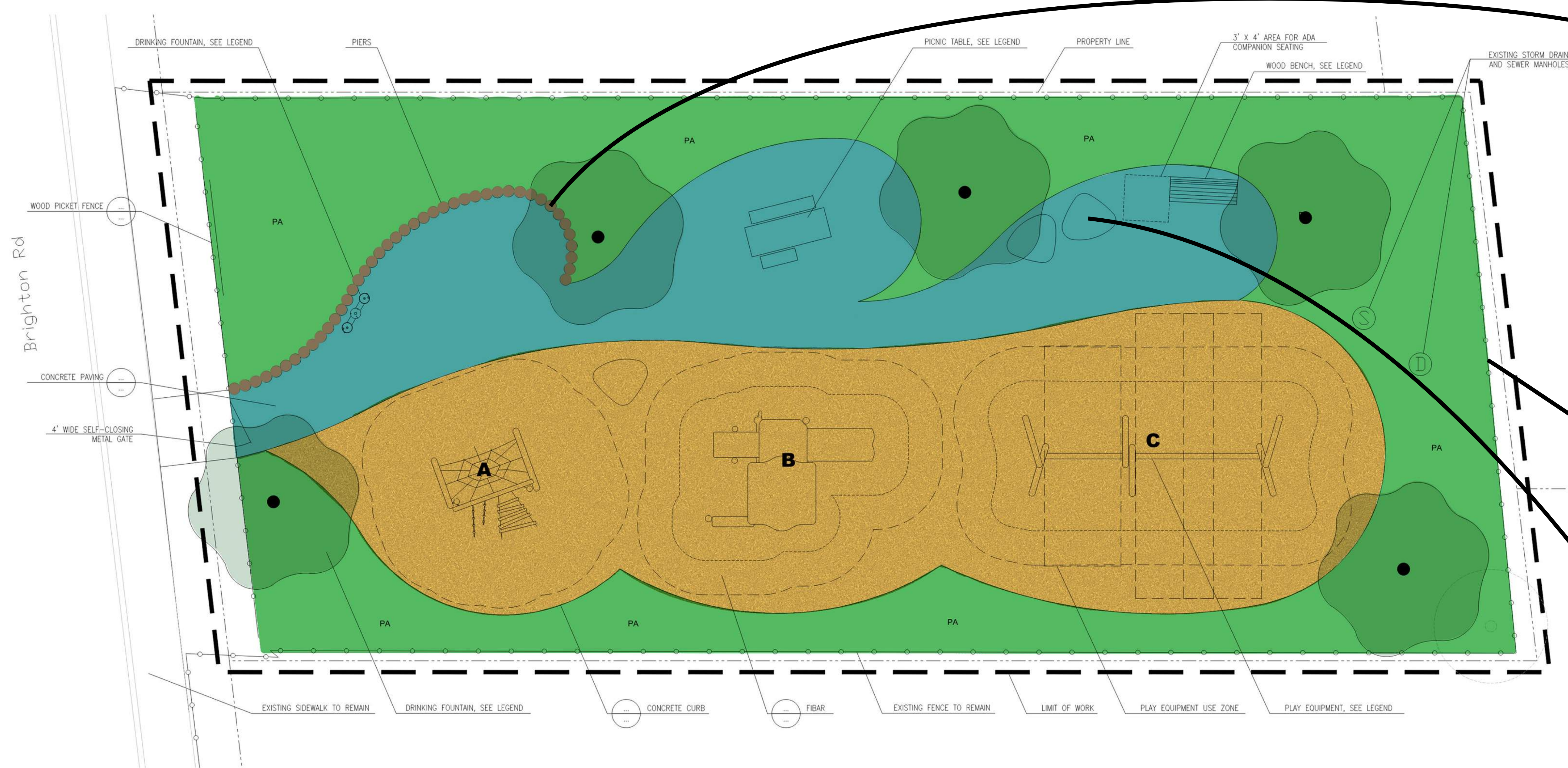

MATERIAL PLAN

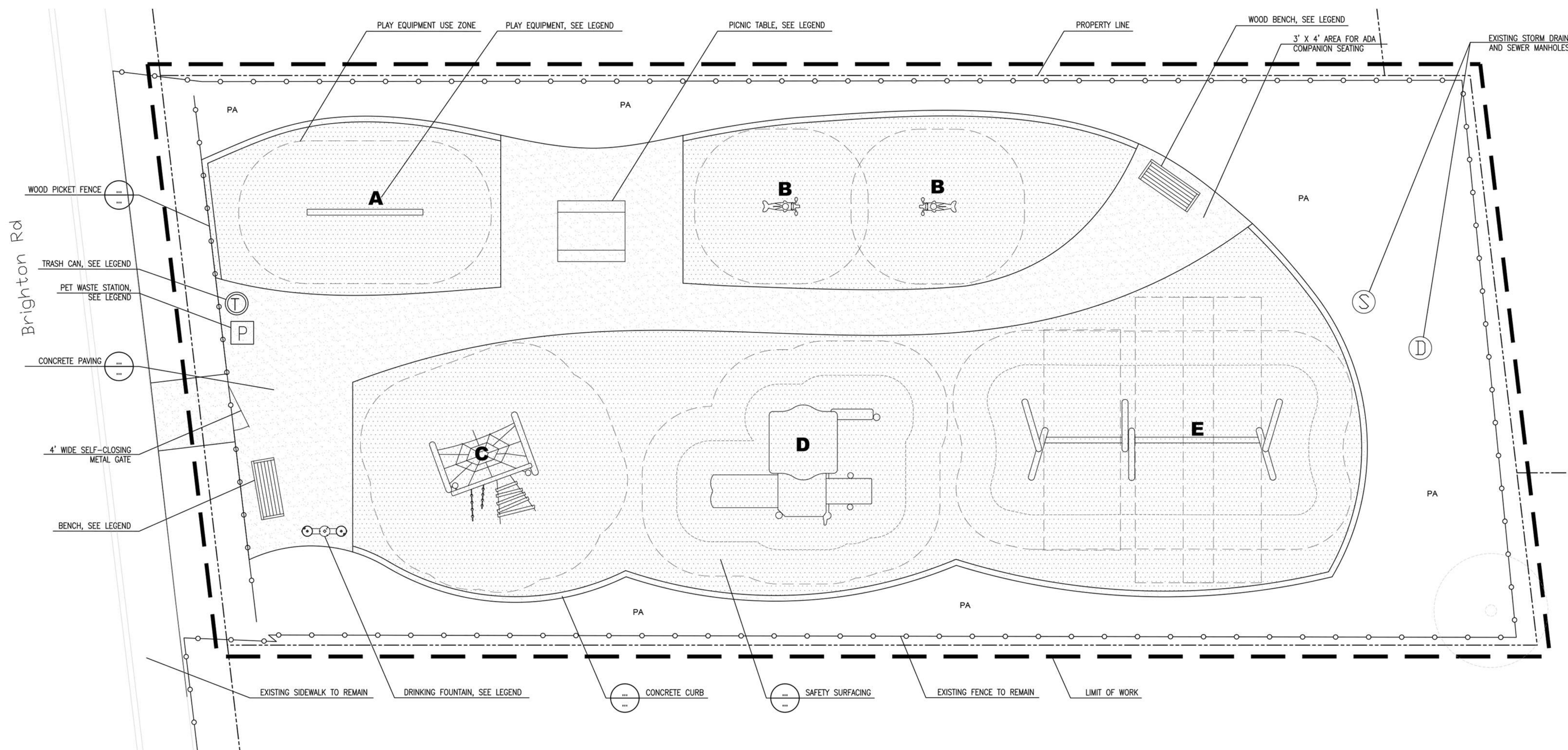

MATERIAL PLAN

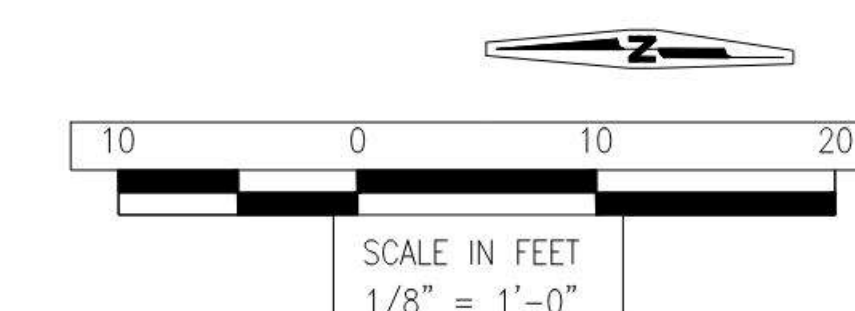

File: P:\Active Projects\Pacificas - 00A\00A.14.55 - City of Pacifica - P101-25 Priority Parks\02 Brighton Park\Brighton Park Material Plan.dwg  
 Printed: 5/11/2023 11:25:53 AM  
 Plot: Pacificas.dwg  
 Plot Date: 5/11/23 11:25:53 AM  
 Plot Scale: 1/8" = 1'-0"  
 Plot Size: 11.00 x 17.00  
 Plot Orientation: Landscape  
 Plot Color: Black  
 Plot Lineweight: 0.20  
 Plot Linetype: Solid  
 Plot Font: Arial, 10  
 Plot Title: Brighton Park Material Plan



CITY OF PACIFICA FOR  
 PRIORITY PARKS

OWNER

CITY OF PACIFICA  
 540 CRESPI DRIVE,  
 PACIFICA CA 94044

NO.	DATE	DESCRIPTION
	5/11/2023	65% SUBMITTAL

PROJECT NO.:	1004.14.55
DESIGNED BY:	MSG
DRAWN BY:	CDV & IMA
CHECKED BY:	MSG DATE 5/11/23
DATE:	5/11/23

This drawing is the property of NCE, including all patented and patentable features, and/or confidential information and its use is conditioned upon the user's agreement not to reproduce the drawing, in whole or part, nor the material described thereon, nor the use of the drawing for any purpose other than specifically permitted in writing by NCE.

SHEET TITLE

MARVILLA PARK  
 DEMO AND  
 MATERIAL PLAN

DRAWING

**L 2.1.0**

SHEET 9 OF 28

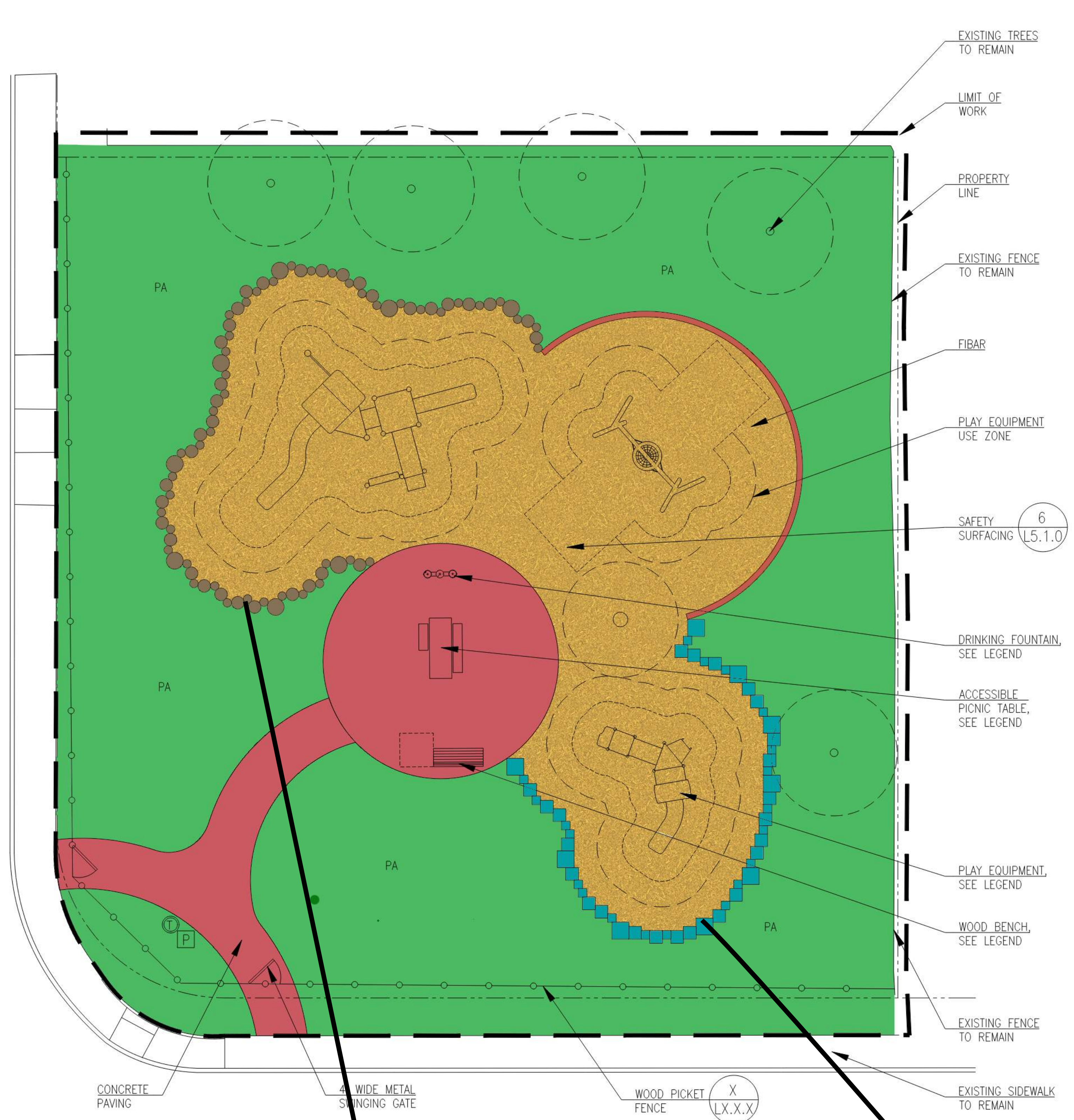

MATERIAL PLAN

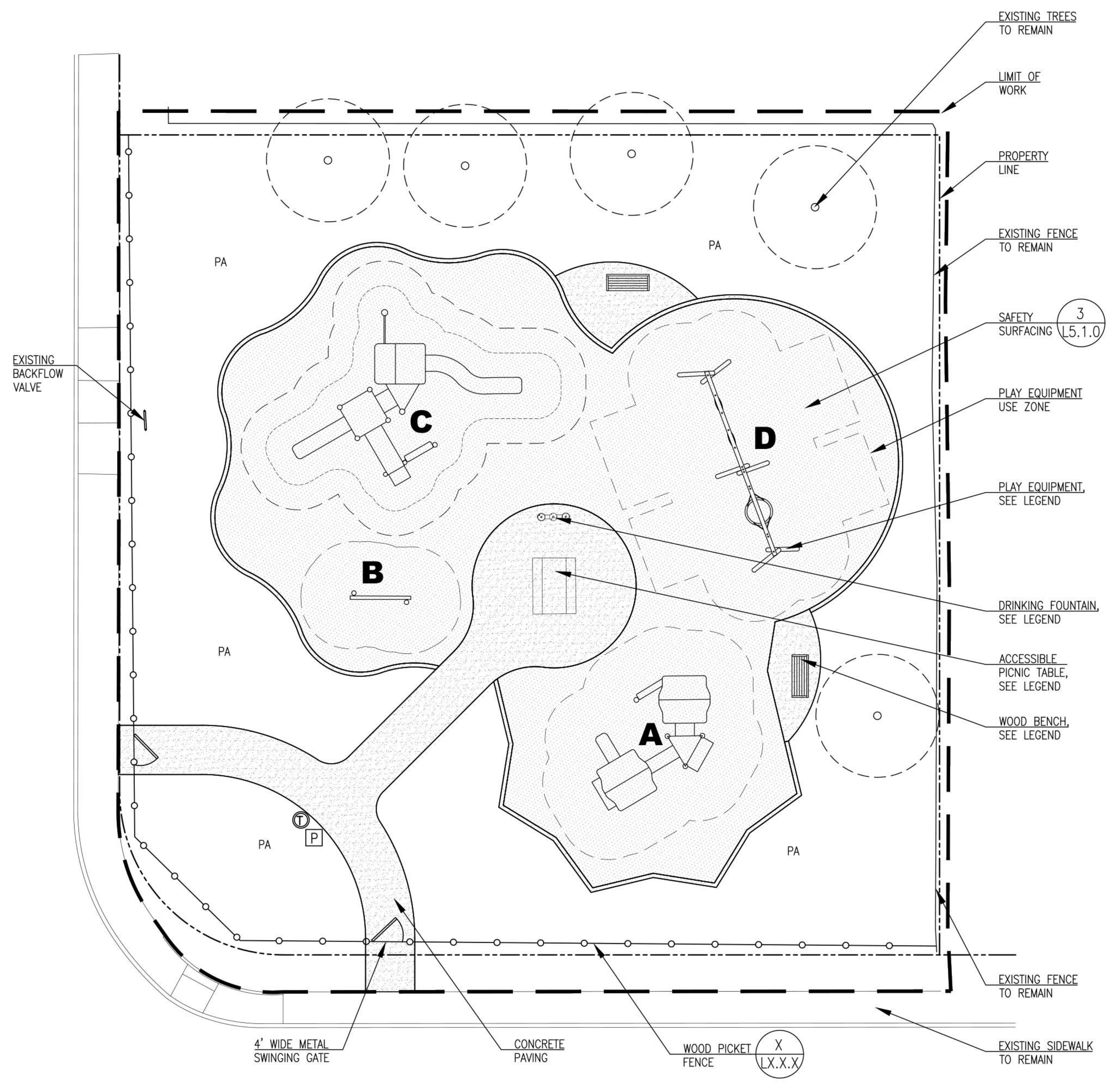

MATERIAL PLAN



ROUND CONCRETE BLOCKS

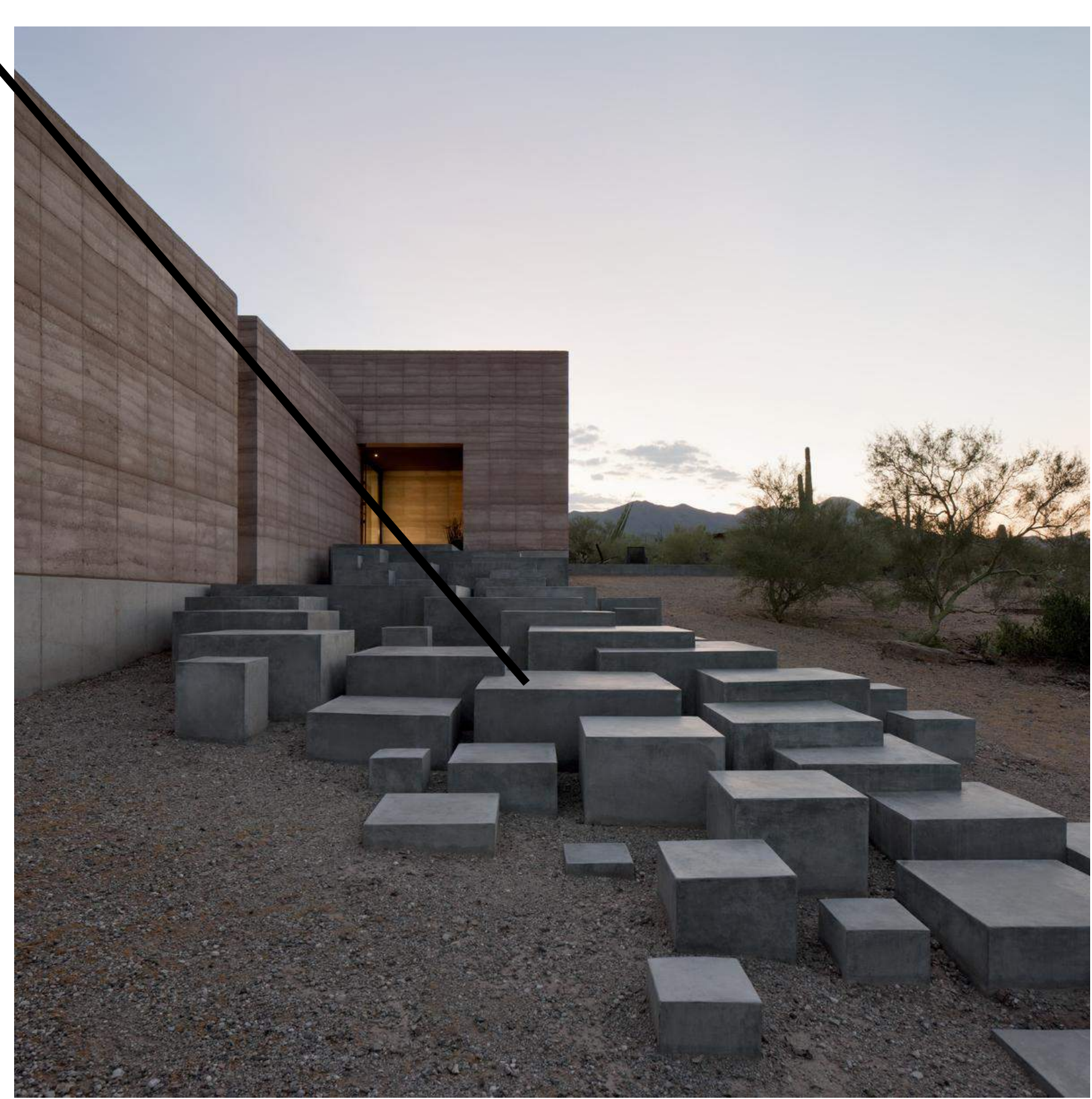

SQUARED CONCRETE BLOCKS

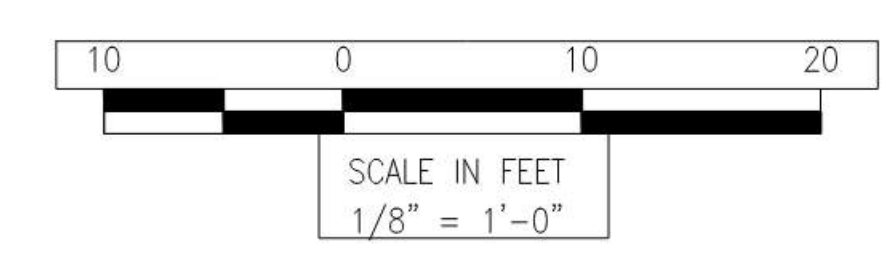

File: R:\Active Projects\Pacifics - City of Pacifica\1721-25 Priority Parks\03 Material Plan\Material Plan.dwg | Project: Marvilla Park Demo and Material Plan | Printed: 5/11/2023 9:24:56 AM | User: NCE

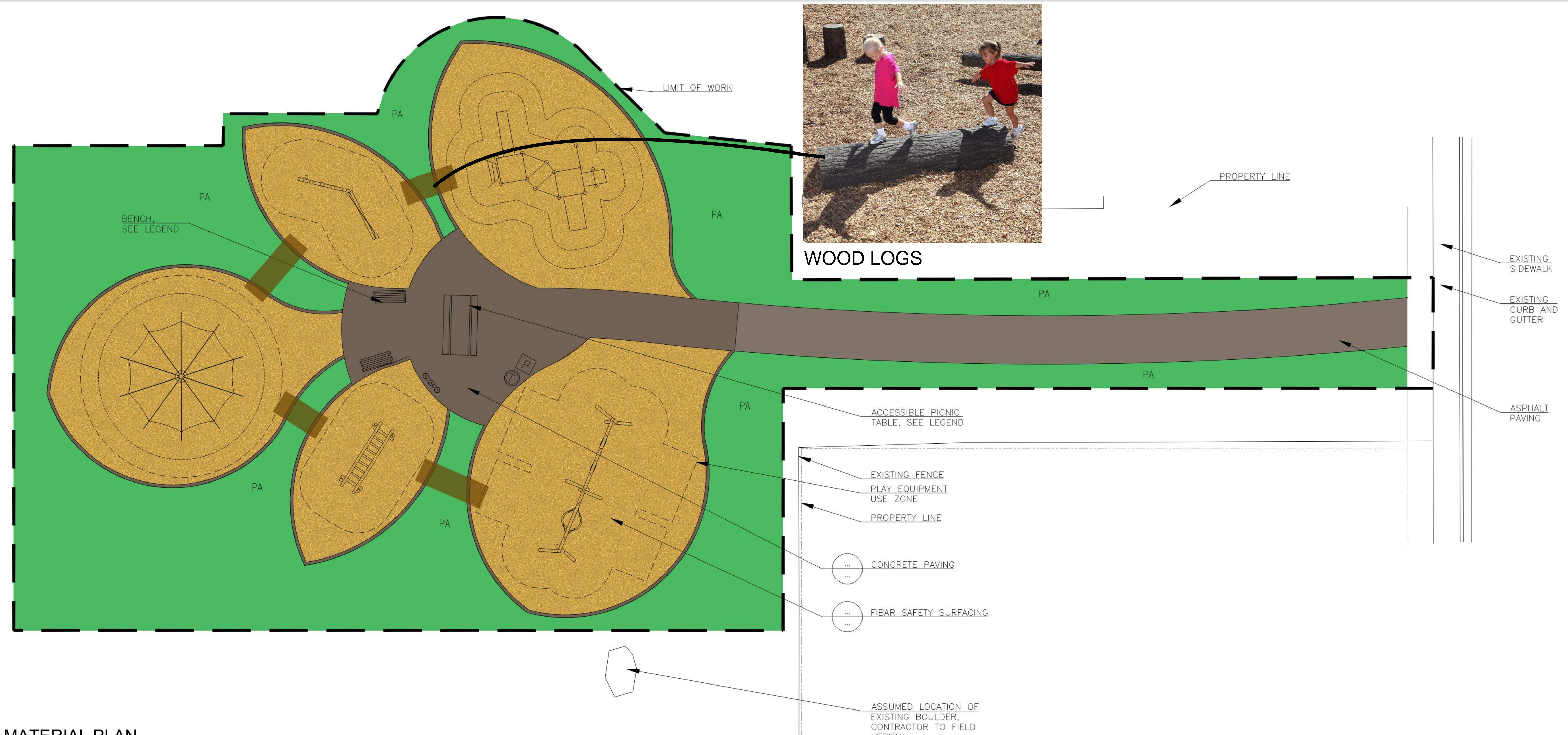

CITY OF PACIFICA FOR  
 PRIORITY PARKS

OWNER

CITY OF PACIFICA  
 540 CRESPI DRIVE,  
 PACIFICA CA 94044

NO.	DATE	DESCRIPTION
	5/11/2023	65% SUBMITTAL

PROJECT NO:	1004.14.55
DESIGNED BY:	MSG
DRAWN BY:	CDV & IMA
CHECKED BY:	MSG DATE 5/11/23
DATE:	5/11/23

This drawing is the property of NCE, including all patented and patentable features, and/or confidential information and its use is conditioned upon the user's agreement not to reproduce the drawing, in whole or part, nor the material described thereon, nor the use of the drawing for any purpose other than specifically permitted in writing by NCE.

SHEET TITLE

IMPERIAL PARK  
 MATERIAL PLAN

DRAWING  
**L 3.1.3**

SHEET 17 OF 28

MATERIAL PLAN

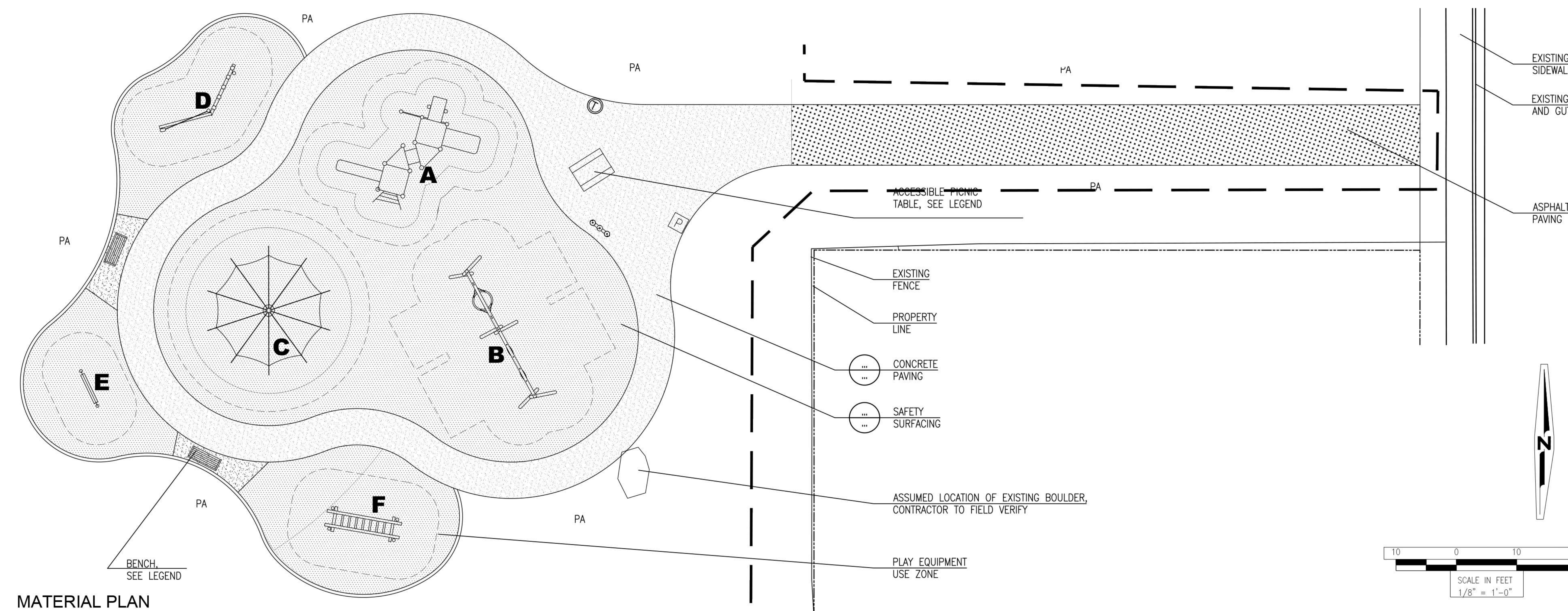

MATERIAL PLAN

File: R:\Active Projects\Imperial Park - City of Pacifica\171-25 Priority Parks\04\Imperial Park\Imperial Park Material Plan.dwg  
 Legend: Imperial Park Material Plan  
 Printed: Sep 11, 2023 @ 11:01am - E:\imperial.dwg  
 Plot: R:\Active Projects\Imperial Park - City of Pacifica\171-25 Priority Parks\04\Imperial Park\Imperial Park Material Plan.dwg  
 Legend: Imperial Park Material Plan  
 Printed: Sep 11, 2023 @ 11:01am - E:\imperial.dwg





MATERIAL PLAN

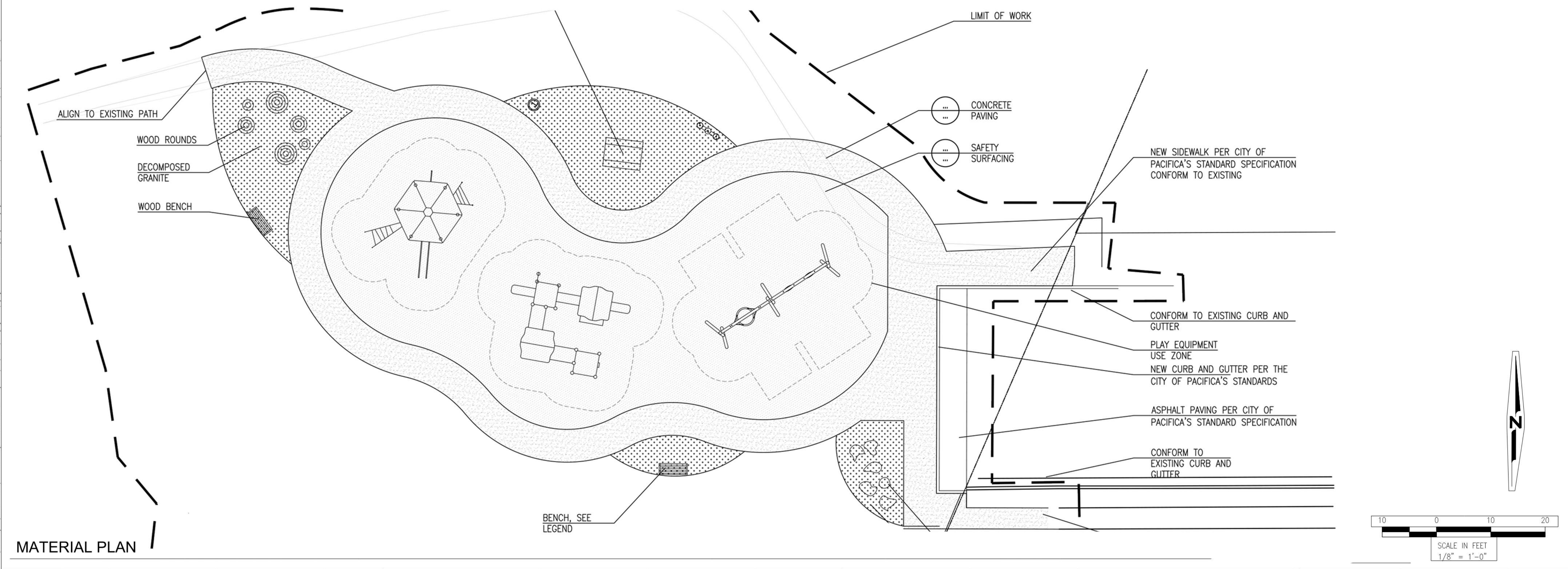

MATERIAL PLAN



CITY OF PACIFICA FOR  
 PRIORITY PARKS

OWNER

CITY OF PACIFICA  
 540 CRESPI DRIVE,  
 PACIFICA CA 94044

NO.	DATE	DESCRIPTION
	5/11/2023	65% SUBMITTAL

PROJECT NO.:	1004.14.55
DESIGNED BY:	MSG
DRAWN BY:	CDV & IMA
CHECKED BY:	MSG DATE 5/11/23
DATE:	5/11/23

This drawing is the property of NCE, including all patented and patentable features, and/or confidential information and its use is conditioned upon the user's agreement not to reproduce the drawing, in whole or part, nor the material described thereon, nor the use of the drawing for any purpose other than specifically permitted in writing by NCE.

SHEET TITLE

**SKYRIDGE PARK  
 MATERIAL PLAN**

DRAWING

**L 4.1.2**